

MONTANA[®]

CRYSTAL CC RACE

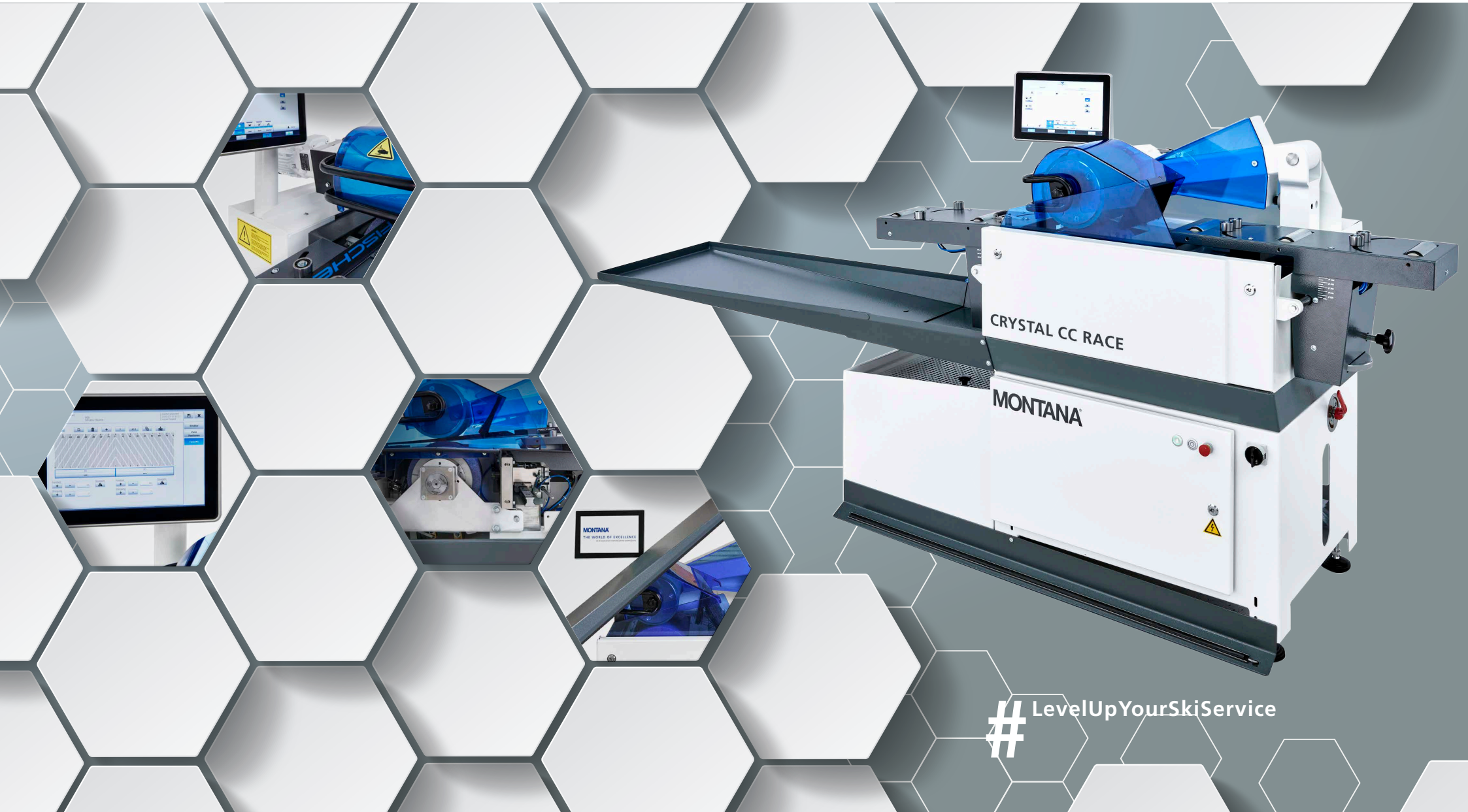

LevelUpYourSkiService

CRYSTAL CC RACE

PRECISION MEETS FLEXIBILITY

FIRST CHOICE FOR RACE SERVICE



The CRYSTAL CC RACE is the innovative racing stone grinding machine for cross-country and alpine skiing. Thanks to its light weight and compact design, the CC RACE is extremely flexible and can be used anywhere, offering unbeatable performance and quality. The continuous precision and high-quality workmanship leave nothing to be desired and are indispensable in racing service.

The latest innovation from MONTANA is characterised by perfection for all cross-country and alpine skis. Offering decisive advantages in racing, where reproducible results and maximum precision are essential, the CC RACE is the perfect solution.

The integrated structure editor (Vario-RACE) gives the user almost limitless possibilities for individual structuring. The 4-point ski centring gives you optimum precision for your race service. The integrated 12-inch touch panel with intuitive user guidance also supports you in your daily work.

The speed of the stone and the feed can be infinitely adjusted to suit your individual requirements. It is also possible to customise the feed variants between the roller and go-kart.

REPRODUCIBLE RESULTS AND MAXIMUM PRECISION FOR A TOP RACE SERVICE

BENEFITS



- Plug & play installation
- Remote maintenance
- Dresser is set electrically
- Feed roller rubberised or go-kart selectable
- High-quality 12" touch panel
- Structure editor with Vario Race offers limitless possibilities for custom structuring
- Cross-feed planing with ball screw
- Ball screw and servo motor
- Two structures on one stone
- 4-point ski centring with 3 cross positions
- Infinitely adjustable stone speed
- Infinitely adjustable feed speed
- Pneumatically adjustable contact pressure
- High-precision stone shaft bearing with ETP
- Stone cleaning with Plexi
- Stone flange for single or dual grindstone

TECHNICAL DATA

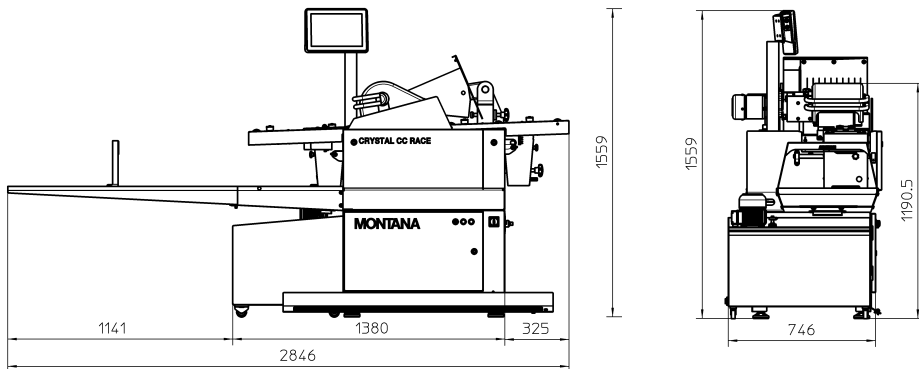

Power:	7 kW
Voltage:	3 x 400 V / 50 Hz or 3 x 220 V / 50/60 Hz
Fuse:	3 x 16 A
Tank capacity:	90 L
Stone speed:	200–2,000 rpm
Cutting speed:	1–34 m/s
Feed:	3–35 m/min
Compressed air:	min. 6 bar 80 l/min
Total weight without emulsion:	440 kg

PRODUCT COMPARISON

TECHNICAL FEATURES



	CRYSTAL INLINE II BASIC	CRYSTAL INLINE II RACE	CRYSTAL CC RACE
SKI	●	●	●
SNOWBOARD	●	●	
CROSS COUNTRY	●	●	●
UPGRADEABLE TO RACE PACKAGE	●		
PLUG & PLAY INSTALLATION	●	●	●
TOOL-FREE BELT REPLACEMENT	●	●	
DRESSER IS SET PNEUMATICALLY	●	●	
DRESSER IS SET ELECTRICALLY			●
PNEUMATICALLY ADJUSTABLE CONTACT PRESSURE	●	●	●
TWO STRUCTURES ON ONE STONE	●	●	●
INFINITELY ADJUSTABLE STONE SPEED	●	●	●
INFINITELY ADJUSTABLE FEED SPEED	●	●	●
HIGH-QUALITY 12" TOUCH PANEL	●	●	●
REMOTE MAINTENANCE	●	●	●
EASY MODE PROGRAMS	●	●	●
STRUCTURE EDITOR (VARIO) FOR LIMITLESS STRUCTURING		●	●
PLEXI STONE CLEANING		●	●
CENTRING UNIT		●	
4-POINT SKI-CENTRING WITH 3 TRANSVERSE POSITIONS			●
DESIGNED FOR RACE SERVICE			●