



LEG SIMULATOR



NORM SOLE



SPECIAL FIXATION FOR
TOURING BINDINGS



FULLY AUTOMATIC
LATCHING



TOUCH SCREEN WITH NEW
OPERATOR GUIDANCE &
CARD-READER



SIGNATURES PAD
COLOUR



JETBOND SK
OPTIONAL BASE FRAME



JETBOND ST
STANDARD VERSION

JETBOND ST / SK

JETBOND is a very morn development in the area of ski binding adjustment devices. Now even faster with new, intuitive operator guidance.

Binding adjustment made fast and easy:

In less than two minutes the JETBOND calculates and proofs the optimal adjustment, very precise, without strain and with implementing the data over a colour touch-screen with intuitive user guidance or with a card reader.

FAST

The unique and patented JETBOND system which automatically closes and snaps in the boot makes it possible to have all the required data in less than 2 minutes, including detection, adjustment and checking of the bindings settings.

EASY

JETBOND can be used without any effort. The leg simulator is fixed to the device and has to be put into the boot. After that the measuring procedure starts and runs completely automatic.

PRECISE

JETBOND is simulating the real stress very accurately. Thanks to a real torque measuring around the front binding, highest accuracy of the results is achieved.

ADVANTAGES

- The flexible JETBOND quick release system allows a fast and problem free spanning of all different kinds of binding and skis
- The leg simulator is fixed permanently and the bringing in of the arm is fast and problem-free.
- The simulating leg adjusts automatically
- The binding is closed automatically
- The binding can be readjusted during the measuring procedure
- No height adjustment needed
- PC with Windows XP embedded
- Thanks to the interface to the rental system the prescribed ISO checking is made easy
- Client data is compatible with other ERP systems
- Precise calculation of the adjustment numbers after ISO 11088 and ISO 8061. You can choose between the tibia or weight method.
- The simulating leg simulates the free torque perfectly and allows a very accurate and close to reality check
- Remote service via Internet

OPTION

- Table with wheels and card deposit
- Card printer
- Scanner
- Scanner holder
- Norm boot sole for a fast pre-season check in the rental business
- Interfaces with rental software (SPORTS RENTAL)
- Interfaces with Jetbase data base for correction factors in the rental business
- Electronic data saving of measure and clients data
- Special fixation and software module for touring bindings
- Signatures pad (optionally with holder)
- Data import from rental software
- Data input via Checkin Terminal



JETBOND TYP ST



JETBOND TYP SK

DIMENSIONS ST/SK

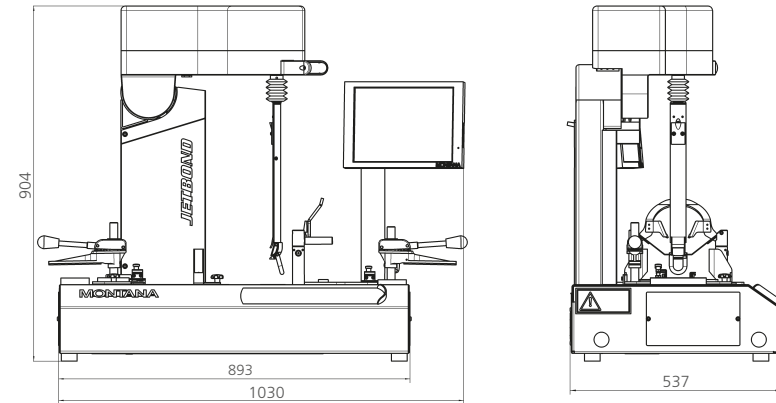

TECHNICAL DATA	JETBOND ST/SK
Voltage:	230 volt / 50/60 Hz or 115 volt / 50/60 Hz
Rated power:	400 watt
Fuses:	4 A
DIMENSIONS	
Length:	1.030 mm
Width:	537 mm
Height:	904 mm
Total weight:	104 kg
Weight table:	47 kg